

installation instructions

Compleo eCLICK

for Compleo eBOX smart, professional und touch

(Generation 3.5)



Content

04 Safety information

- Qualifications for electrical work 5
- Electric vehicle charger characteristics according to IEC 61851-1 Ed. 3 6
- General and electrical specifications 7

08 Product overview

- Included in delivery 8
- Compleo eCLICK – the product details 9
- Specifications 9

10 Prior to installation

- Choosing the site 10
- Ergonomics 10
- Pre-installation requirements 11
- Cable selection 11
- Routing the connecting cable 11

12 Installation

- European grids 14
- Tools needed 16
- Notes on installation 17
- Installation in Compleo ePOLE duo 17
- Compleo eCLICK wall installation 18
- Compleo eSMARTMETER integration (optional) 20
- Supply cable connection 20
- Compleo eSMARTMETER cabling 21
- Preparing the electrical connection 22
- Ethernet connection (optional) 22
- Shunt release connection (optional) 24
- Grid control box connection (optional) 24

- Electrical connection 26
- Connection options 26
- Scenario A: Compleo eCLICK electrical connection without Compleo eSMARTMETER, simple supply 27
- Scenario B: Compleo eCLICK electrical connection with Compleo eSMARTMETER, simple supply 28
- Scenario C: Compleo eCLICK electrical connection without Compleo eSMARTMETER, double supply 29
- Scenario C: Compleo eCLICK electrical connection with Compleo eSMARTMETER, double supply 30
- Reading the meter 31
- Almost done: electrical tests and sealing 31

32 Clicking the Compleo eBOX into the Compleo eCLICK

35 Commissioning the Compleo eBOX

- Configuring the power connection 37
- Maintenance/repair 37
- Disassembly 38
- Disposal 38

- Imprint 39

Safety information

DANGER

Danger to life and limb



Warning of electrical voltage!

IMPORTANT

Considerable risk of injury/damage to property



IMPORTANT! There is a risk of injury or damage to property!
The eCLICK must be installed by qualified, specialised electricians.

NOTE

Hinweis zur Optimierung der Anwendung



Observing this information can improve the product's application.

The eCLICK must be installed by qualified, specialised electricians. In general, priority must be given to the accident prevention regulations, the safety rules applying nationwide to the specific operations, and the medical regulations at the workplace.

The product can only be commissioned free of faults if this document is observed. These installation instructions constitute an integral part of the product and must be available to the installers even after the installation. Therefore, keep this document in a safe place even after installation.

Note in addition that safety is ensured only when the devices in question are stored, installed, used, serviced, and, if necessary, disassembled and disposed of properly as described in this document.

• Before installing and using this product, please read the provided documentation to familiarise yourself with the safety regulations and other information.

- This product was developed and tested in compliance with international standards.
- This product may be used exclusively for its intended purpose.
- This product must be installed by qualified personnel exclusively.
- This product is maintenance-free and cannot be repaired on site.
- Incorrect installation may entail risks for the user.
- This product is used in combination with a power source.
- Make sure that the product is only used in proper operating conditions.
- Make sure that the power supply to this product is connected properly to a fuse box with RCD and circuit breaker as described below in this document.
- The selected RCD and circuit breaker must be suitable for the electrical connection and installed in an upstream fuse box.
- Make sure that the fitted RCD is serviced at the intervals specified by the manufacturer.

Before installing, check the specifications under the grid connection regulations, the technical connection requirements, and those issued by the utility with respective national requirements and specifically follow the compulsory registration, approval, and listing procedures.

Product subject to modification without prior notice. This document might not contain the latest changes to the product's specifications or processes described herein.

**Danger**

Handling live components incorrectly may cause grievous injuries and death. So heed at all times the five safety rules under DIN VDE 0105:

- Disconnect from all power sources
- Lock against reactivation
- Verify zero voltage (all poles)
- Earth and short circuit
- Cover or partition-off adjoining live parts

**Danger**

Turn off circuit before remounting or replacing the eBOX.

**Important**

eBOX bases have sharp edges. Do not grasp the eBOX by the bases.

**Important**

Technically non-functioning or defective charging infrastructure must not be used. In addition, do not use any charging infrastructure that does not comply with the intended use or the conditions specified by the manufacturer or which is not regularly checked.

**Important**

Make sure that all components are dry during installation.

**Important**

The contents of the delivery must be checked for completeness and intactness.

**Important**

Keep equipment pack away from small children. There is a risk that small parts could be swallowed by children, resulting in death. Do not install in the presence of children.

**Important**

Check that the warranty seal on the back of the eBOX is intact. Do not operate the product unless the warranty seal is undamaged. Damaged warranty seals void the warranty.

**Important**

It is recommended not to install the eBOX in areas where electromagnetic emissions from large industrial facilities may interfere with communication.

**Important**

When selecting the installation location, please ensure that the eBOX is not exposed to permanent sunlight.

**Important**

Ensure that no flammable or combustible materials are stored at a distance of less than 5 m from the charging infrastructure and that no fire is lit.

**Note**

eBOX professional is a maintenance-free product. It does not contain any repairable parts or components. Do not carry out any repair work. In case of a permanent error, replace the eBOX.

**Note**

This is a CE-certified product. All relevant product standards and rules and regulations applicable to the product are confirmed in the product's EC Declaration of Conformity.

Qualifications for electrical work

The specialised personnel performing or supervising the electrical installation and maintenance of the device must have read and must follow these installation instructions. Also, this personnel must have been assigned by the system owner.

Germany

Applicable are the requirements under DGUV Regulation 3 or DIN VDE 0105-100:

- Technical training (electrical installations)
- Knowledge and experience in the assigned field of work
- Knowledge of the pertinent standards
- Ability to assess the assigned work
- Ability to recognise dangers

Austria

Applicable are the requirements under ÖVE/ÖNORM EN 50110-1:

A specialised electrician is a "person who has undergone suitable technical training and has the knowledge and experience to recognise and prevent the potential dangers of electricity".

Switzerland

Applicable are the requirements under NIV, SR 734.27:

“Section 2: Approval for installation work, Subsection 1: Compulsory approval, Art. 6

Persons assigned to install, modify, or repair electrical installations, hardwire electrical products to electrical installations, or disconnect, modify, or repair such connections must first be approved by the Inspectorate.

Subsection 2: General installation approval, Art. 7 – Approval for natural persons

Natural persons performing installation work on their own responsibility are granted general installation approval when:

- b) their training corresponds to the state of the art and their continued training is assured; and
- c) they can furnish verification that they obey the regulations under this ordinance.”

Electric vehicle charger characteristics according to IEC 61851-1 Ed. 3

1. The product must be connected to an AC mains.
2. The product is connected permanently to the mains.
3. The product is compatible with the eBOX smart/professional/touch charger in the variants with type-2 socket, type-2 plug, and connected cable.
4. The product is compatible with electric vehicles charged with AC in mode 3.
5. The product can be installed and used in protected indoor areas and unprotected outdoor areas exposed to rain and direct sunlight (IP protection only after eBOX installation).
6. The product can be used in closed-off and public areas.
7. The product can be installed on walls and to compatible POLE (ePOLE or ePOLE duo) products.
8. The product eCLICK in conjunction with the eBOX is rated electrical protection class I. The open eCLICK is rated electrical protection class I.



Note

This is a CE-certified product. All relevant product standards and rules and regulations applicable to the product are confirmed in the product's EC Declaration of Conformity.

General and electrical data	Compleo eCLICK	Compleo ePOLE duo/Compleo eCLICKs in ePOLE duo
Charging power	3.7/4.6/7.4/11/13.8/22 kW (16 A, 20 A, 32 A; one* or three-phase)	
Grid input power	eCLICK: rotating current 400 V AC, three-phase, 32 A (22 kW)/20 A (13.8 kW)/16 A (11 kW) or alternating current 230 V AC, one-phase, 32 A (7.4 kW)/20 A (4.6 kW)/16 A (3.7 kW)	
Output power to eBOX	eCLICK: rotating current 400 V AC, three-phase, 32 A (22 kW)/20 A (13.8 kW)/16 A (11 kW) or alternating current 230 V AC, one-phase, 32 A (7.4 kW)/20 A (4.6 kW)/16 A (3.7 kW)	
Operating temperature	-30 °C to +50 °C	
Storage temperature	-30 °C to +80 °C	
Weight	1.1 kg	
Protection class	Protection class I	
eSMARTMETER (MID-compliant)	optional for eCLICK, MID-compliant (Europe) and CE certified; can be optionally screwed and wired into eCLICK	
max. wire cross-section	Max supply line (top or bottom): 10 mm ²	Max supply line (bottom only): 10 mm ²
Certifications	CE (tested and confirmed by certified body); UKCA	
Packaging dimensions (W x D x H)	515 mm x 225 mm x 75 mm	

Recommended additional accessories	Compleo eCLICK	Compleo ePOLE duo/Compleo eCLICKs in ePOLE duo
Personal protection to be installed in sub-distribution per charging point	Fault current protection switch type A (RCD type A): 32A connection: ABB F204A-40/0.03, type A, 4-pole (short time delay, operating voltage: 230/400 V AC) 16A connection: ABB F204A-25/0.03, type A, 4-pole (short time delay, operating voltage: 230/400 V AC)	
Short circuit/overload protection to be installed in sub-distribution per charging point	Automatic cut-out: 32A connection: ABB S203-NA K40A (rated breaking capacity: 6,000 A) 16A connection: ABB S203-NA K20A (rated breaking capacity: 6,000 A)	

* 32 A one-phase is not permitted in all EU countries.
Please check the country-specific conditions.

Protection devices from other manufacturers with properties identical to those described here can also be used.

Product overview

The eCLICK is the docking station for the eBOX variants. Together, eCLICK and eBOX form the charger for eMobility solutions. Thanks to its modular design, the eCLICK can also be installed without the eBOX, which is then fitted at a later time. Please observe the safety instructions at the beginning of these installation instructions. The eCLICK can be mounted on a suitable wall or in the ePOLE (duo).

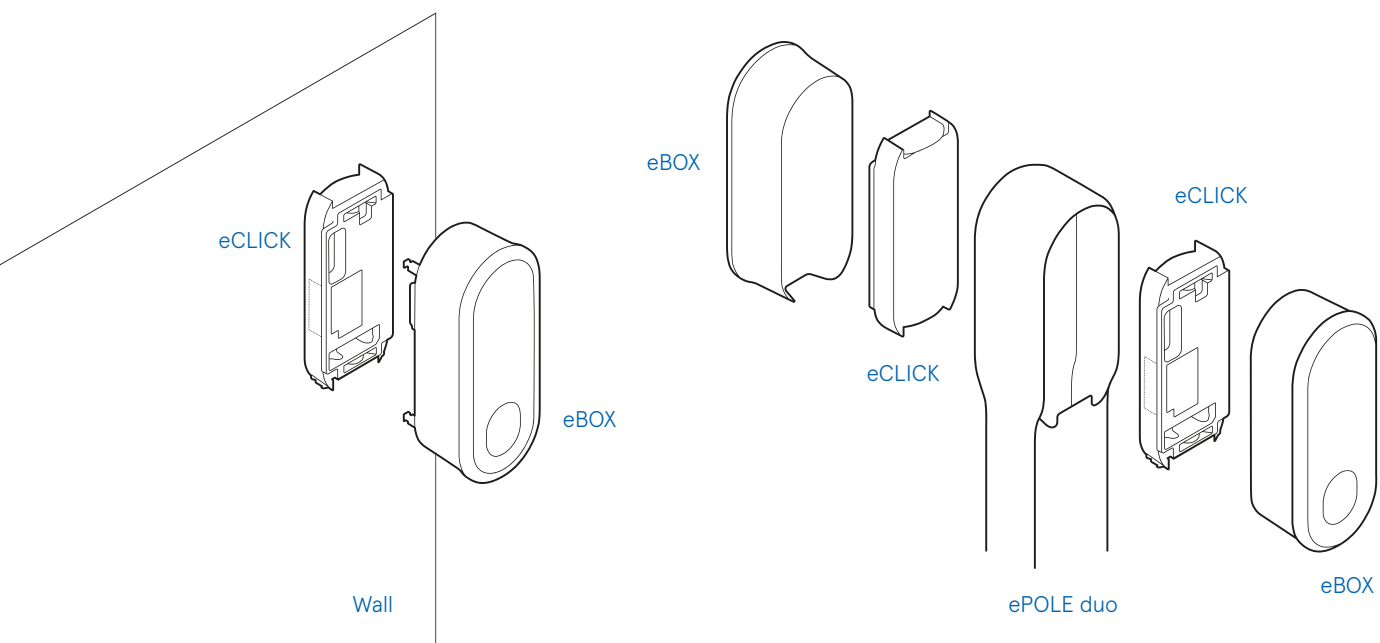

Included in delivery

- 1 eCLICK
- 1 multilingual installation instructions
- 1 drilling template

Equipment pack:

- 3 sealing plugs
- 3 universal dowels
- 3 round head screws 6x59 mm
- 1 cable gland M20 x 1.5
- 1 lock nut M20 x 1.5
- 1 sealing ring
- 1 seal
- 1 screw for cable clip
- 1 cable clip

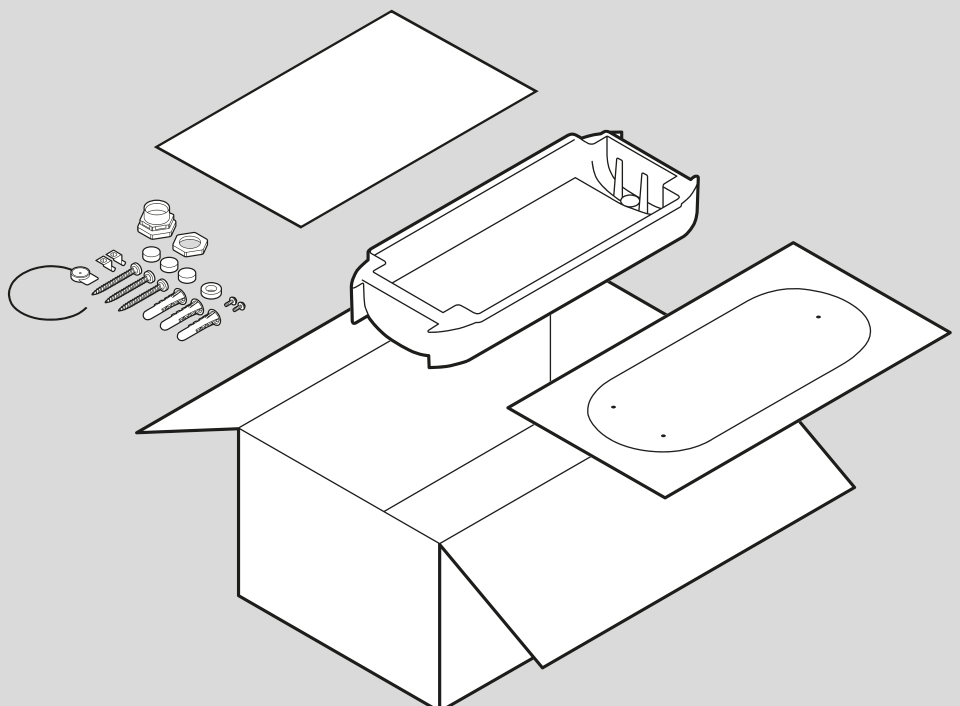

Important

The contents of the delivery must be checked for completeness and intactness.

Compleo eCLICK – the product details

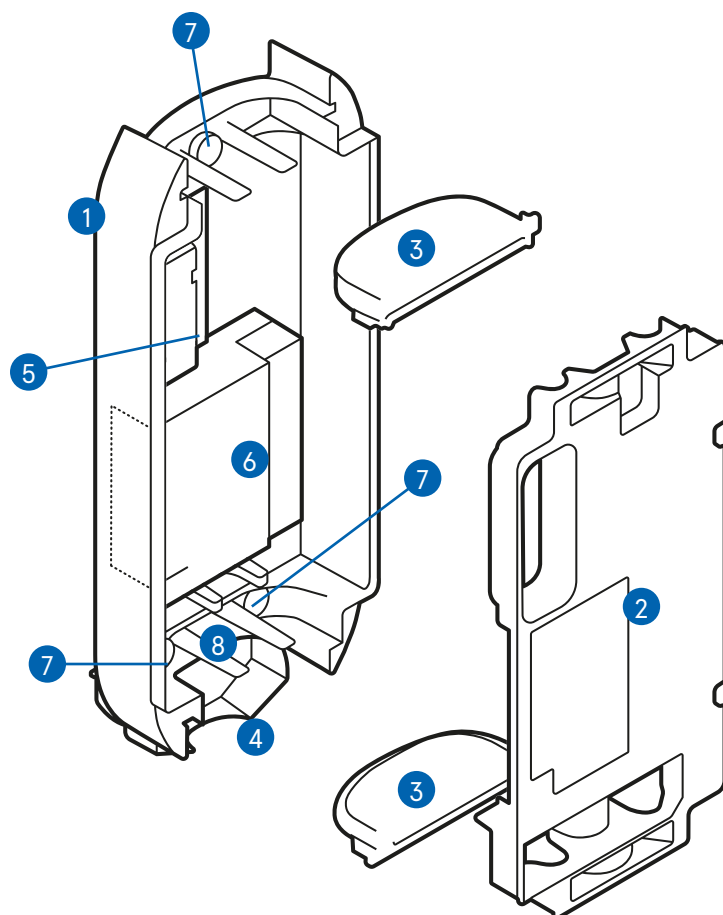

- 1 eCLICK
- 2 Contact guard
- 3 Cable routing plates
- 4 Locking bracket
- 5 Mains board
- 6 eSMARTMETER (optional)
- 7 Sealing plug
- 8 Interface board

Specifications

Measurements H x W x D	Approx. 399 mm x 155 mm x 62 mm
Installation type	Wall; ePOLE and ePOLE duo
Weight	Approx. 1 kg (without eSMARTMETER)
Protection rating	IP55 (with eBOX)
Operating temperature	-30 °C to +50 °C
Voltage supply	400 V AC, three-phase, + PE + N from sub-distribution 230 V AC, single-phase, + PE + N from sub-distribution
Power supply	16 A or 20 A or 32 A (configurable during commissioning)
Connected load	3.7 kW to 22 kW; maximum load

Before installing

Before installing, check the specifications under the grid connection regulations, the technical connection requirements, and those issued by the utility with respective national requirements and specifically follow the compulsory registration, approval, and listing procedures. Product subject to modification without prior notice. This document might not contain the latest changes to the product's specifications or processes described herein.

Choosing the site

Contact the customer to choose a suitable site. The optimal location for the charging station depends on the owner's requirements and on the parking situation as well as the local conditions for cable routing. The eCLICK can be installed to a wall or to ePOLE (duo), depending on the customer's requirements. Make sure that the surface is suitable for installation; for wall installation, strength grade 12 or higher is recommended.

For wall installation, also ensure that the surface on which the eCLICK is to be installed is even. If the surface is uneven, it may be difficult to install and moisture may penetrate.

A generous distance (recommended is 0.5 m, depending on the ambient temperature) between the eCLICK and surrounding objects ensures adequate heat dissipation and unimpeded use later.

When positioning the eBOX, please ensure that it is accessible even with parked vehicles so that the cable can be connected to the vehicle and the eBOX without any problems and so the eBOX can be operated without any limitation.

When selecting the installation location, please ensure that the eBOX is not exposed to permanent sunlight.



Danger

Do not install in and around ex-zones!

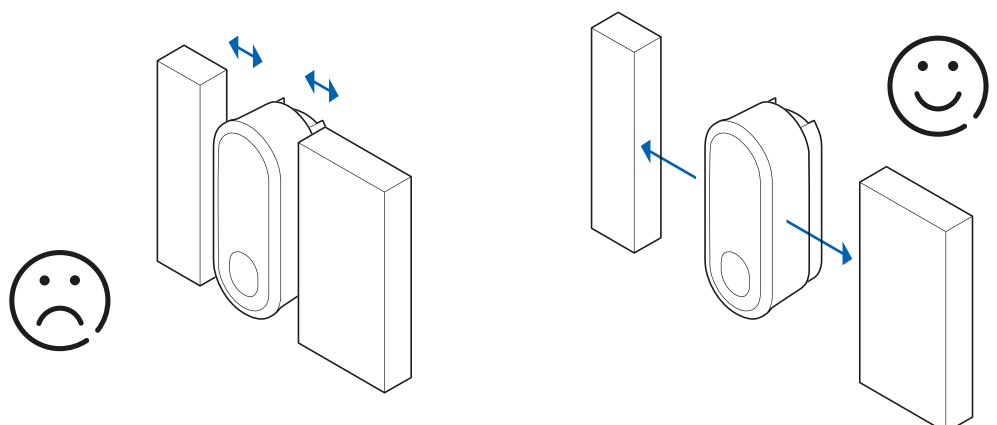

Ergonomics

For good ergonomics, we recommend preparing the location, e.g. a wall. The chapter "eCLICK wall installation" demonstrates the optimal dimensions.

Pre-installation requirements

Check and ensure that the electrical installation intended for connection can supply the required electrical power.

Each eCLICK must be fused with its own RCD and its own circuit breaker in the pre-installation. No additional electrical devices may be integrated in any of these circuits.

Before installing, first consult the owner or operator of the system for the required output power, and fit adequate guards.

Before installation ...

- check the installation of the surge protection device, if required by national standards.
- routing of the connecting line to the installation site must be completed.
- connection of the supply line between the eCLICK/eBOX and the sub-distribution must be prepared.



Important

For reasons of space, select a supply cable with $\leq 6 \text{ mm}^2$ cross-section if possible.

From a thermal point of view, a 10 mm^2 supply cable must be selected. In addition, the cable cross-section of the supply cable is selected according to its length.

Cable selection

When selecting the cable, valid, international, country-specific and regional regulations and standards must be observed. When selecting the cable, the connection to a three-phase or single-phase AC circuit must be made in accordance with the regulations and standards.

The cable cross-section must be selected so that the self-heating is limited to 15K.

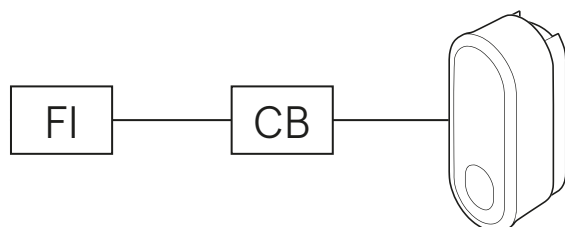

Once the required cables have been routed, the pre-installation is complete.

Routing the connecting cable

Route cables with an adequate conductor area to the site chosen. In doing so, however, bear in mind that only cables not exceeding 10 mm^2 in cross-section may be introduced into the eCLICK (maximum bending radii). The routed cables may therefore have to be rewired before they are inserted into the eCLICK.

To prevent the connection cable from being accidentally cut too short, a cable projection of approx **450 mm** from the cable routing plate should be provided.



Important

When the eCLICK is mounted in the ePOLE side-by-side, ePOLE back-to-back or ePOLE duo, each and every eCLICK must be provided with its own RCD and circuit breaker. As a consequence, two separate supply lines are required.

You may then have to repeat the procedure under the subsections "Before installation" ff. to install the second supply line.

Installation



Danger

Before installing, familiarise yourself with the safety instructions.

Please note that the installation and commissioning of electrical systems and components may only be carried out by qualified personnel.

This section is divided into the main categories preparations prior to installation, installation, and electrical connection, which in turn are divided into subsections of greater detail.

Please note the following summary of the most important installation steps:

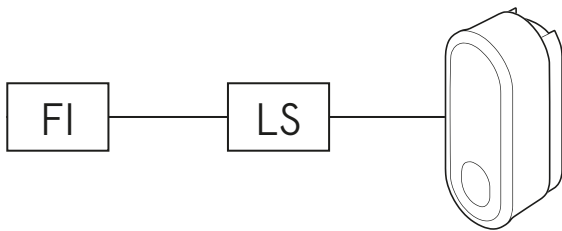

1. Consultation with the grid operator.

2. Checks: Can the system deliver the required power?

3. Site selection and eCLICK installation.

4. Pre-installation: Make sure that a corresponding RCD (see table below) and circuit breaker (see table below) are installed in the sub-distribution.

5. Supply cable: Plan, place, adjust cable routing plate.

6a. Ethernet cable (optional): Before connecting an Ethernet cable, first drill a hole for an M20 thread according to the enclosed cable gland through the corresponding routing plate. Insert the cable gland supplied and fit the lock nut.

6b. Grid control box and shunt release (optional): Before connecting a shunt release, first drill a hole for an M20 thread (as depicted on page 23) according to the enclosed cable gland through the corresponding routing plate. Insert the cable gland supplied and fit the lock nut.

7. eSMARTMETER: Check whether an eSMARTMETER is to be installed in the eCLICK.

7a. Version with eSMARTMETER: If necessary, install the eSMARTMETER in the eCLICK, and connect it to the mains board.

7b. Version without eSMARTMETER: If an eSMARTMETER is not necessary, route the supply line directly to the mains board.

8. Select suitable connection scenario and wire.

9. If single-phase connection is required, the mains board or eSMARTMETERs must not be connected to L2 or L3! Supply line L1 must always be connected to L1 of the mainboard or eSMARTMETER.

10. Make sure that the contact guard is snapped into place in the eCLICK. Use the provided seal to secure the contact guard on the eCLICK in such a manner that unauthorised removal of the contact guard is not possible without breaking the seal.

11. Read the meter.

12. Perform electrical test.

13. Go through checklist, p.34.

RCD

Charging power	3.7 kW; 11 kW	7.4 kW; 22 kW
Charging current	16 A	32 A
Example	F204A, 4-pole, 25/0,03 A ABB	F204A, 4-pole, 40/0,03 A ABB
Standards	DIN EN 61008-1/DIN EN 61008-2-1	DIN EN 61008-1/DIN EN 61008-2-1
Type	A	A
Operating voltage	230/400 V AC	230/400 V AC
Poles	4-pole	4-pole
Rated residual current	30 mA	30 mA
Rated current	25 A	40 A
Tripping time	300 ms	300 ms
Operating characteristics	instantaneous	short-time delayed (AP-R)
Overvoltage category	III	III
Fouling factor	2	2
Ambient temperature	Tmax +55 °C, Tmin -25 °C	Tmax +55 °C, Tmin -25 °C
Material number	10284822	10118695

Circuit breaker

Charging power	3.7 kW; 11 kW	7.4 kW; 22 kW
Charging current	16 A	32 A
Example	S203-NA K, 20A ABB	S203-NA K, 40A ABB
Standards	DIN EN 60947-1, -2/DIN EN 60898-1	DIN EN 60947-1, -2/DIN EN 60898-1
Tripping characteristics	K	K
Poles	4-pole	4-pole
Rated breaking capacity	6,000 A	6,000 A
Rated current	20 A	40 A
Insulation voltage	4 kV	4 kV
Overvoltage category	III	III
Fouling factor	2	2
Ambient temperature	Tmax +55 °C, Tmin -25 °C	Tmax +55 °C, Tmin -25 °C
Material number	10133671	10118694

European grids

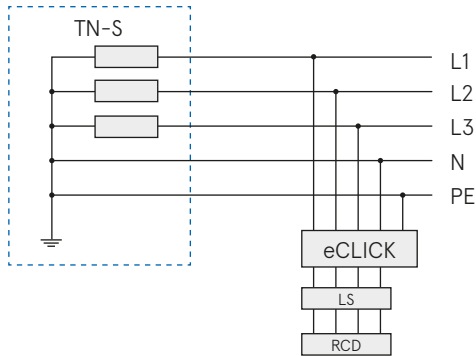

Single-phase connection: L1, N, PE,
three-phase connection: L1, L2, L3, N, PE.

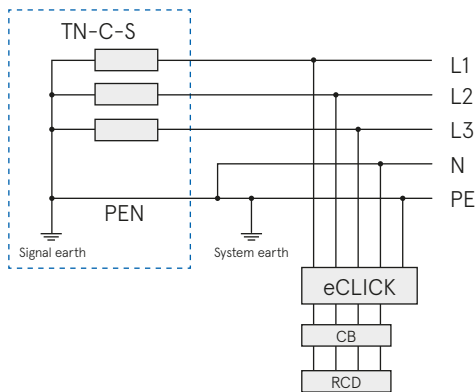

Single-phase connection: L1, N, PE,
three-phase connection: L1, L2, L3, N, PE.

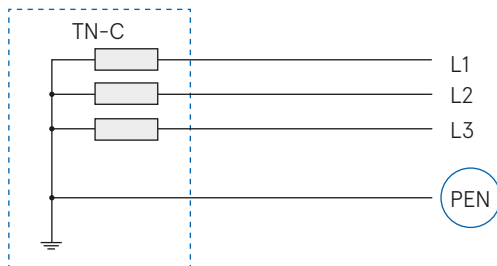

A TN-C mains is **not** supported.
The eCLICK cannot be connected directly
to a TN-C mains.

If the pre-installation presents a transfer
point from a TN-C to a TN-C-S mains, the
eCLICK may be connected to the latter
according to TN-C-S description. In other
words, the TN-C mains must be converted
to a TN-C-S mains.

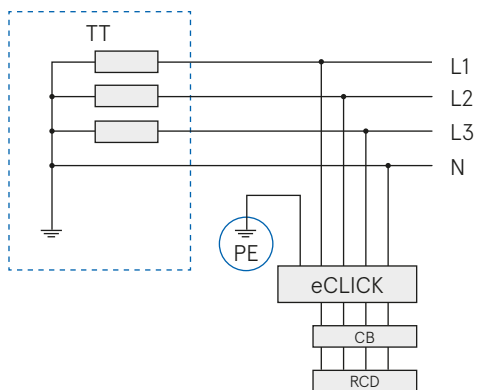

National standards apply.

A suitable earth electrode must be used. The suitability of the earth electrode must be measured to verify its compliance with national standards.

Assuming there is an earth electrode of verified suitability:
 single-phase connection: L1, N, PE,
 three-phase connection: L1, L2, L3, N, PE.

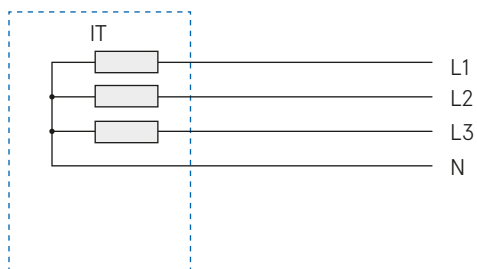

An IT mains is **not** supported. The eCLICK must not be connected directly to an IT mains!



Important

Special requirements must be met for installation in TN-C, TT or IT networks.



Danger

Use only power transmission cables complying with DIN VDE 18015 and designed for voltages of $\Delta U_{max} < 3\%$.



Note

A separate document describes how the ePOLE duo is installed.

Tools needed

To install the eCLICK to a wall or to ePOLE (duo), you will need a spirit level, the drilling template provided in the packaging, a pencil or other marker, an 8 mm drill bit, a screwdriver, an electric drill with step bit, and a cordless

screwdriver with torque display. You will also need a side cutter, a pair of round-nosed pliers, and, for cable assembly, a cable knife and a wire stripper.



Hammer drill

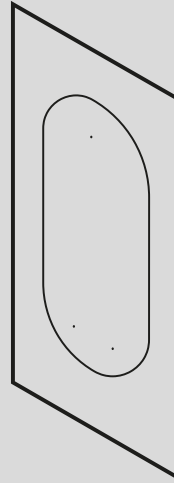

Drilling template

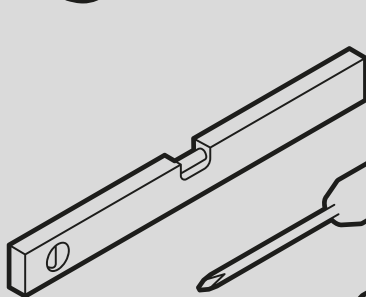

Spirit level

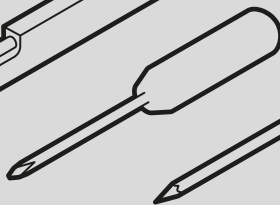

Screwdriver (Phillips, slotted head 4 mm)



Pencil

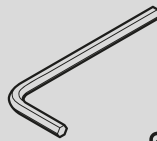

Allen key (3 mm)



Drill bit (8 mm)



Stepped drill bit 10-40 mm for M20 thread (optional for installing an Ethernet cable and/or for wiring a Welding/shunt release indicator relay)

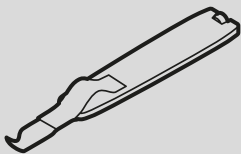

Cable knife

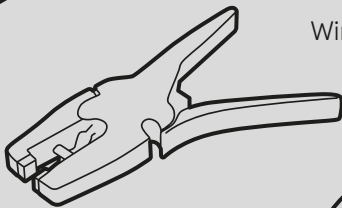

Wire stripper

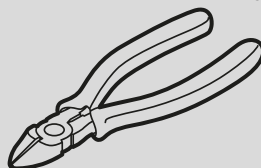

Side cutter

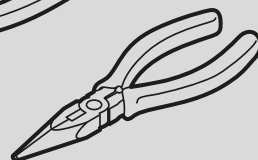

Round-nosed pliers

Installation information

The eCLICK is secured through three screw holes to the wall or the ePOLE (duo). To start, place the rear side of the eCLICK on a flat surface, and remove the contact guard. The contact guard is clipped without screws to the eCLICK. It is only replaced after connecting to the mains.

Use a screwdriver to remove the contact guard. To do this, insert the screwdriver into the slots on the side of the contact guard and carefully lift it.



Danger

This product contains antennas that emit electromagnetic fields that can interfere with other electronic devices such as mobile phones and medical devices when exposed to prolonged periods of time at intervals less than 3.5 cm. If prolonged exposure is expected, a minimum distance of 20 cm is recommended to avoid interference.

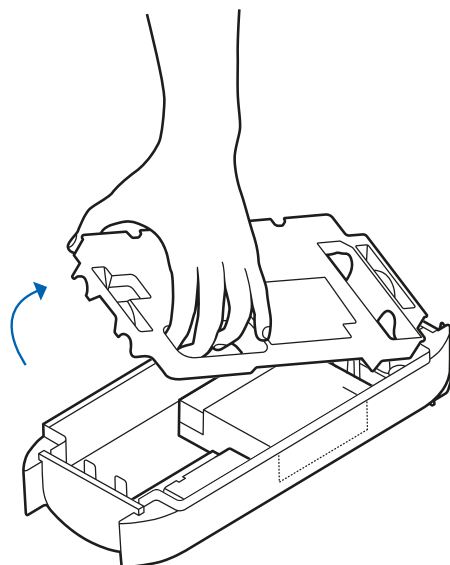

Installation in Compleo ePOLE duo

Remove the insulation plugs from the eCLICK, and screw the eCLICK to the points provided for this purpose in the ePOLE duo. Use the screws (3x M6x16) and washers (3x 6.4)

provided with the ePOLE duo. After securing, replace the insulation plugs. Repeat these steps on the opposite side.



Important

It is imperative that you insert the provided sealing plugs, otherwise water or other substances may penetrate and damage the product.

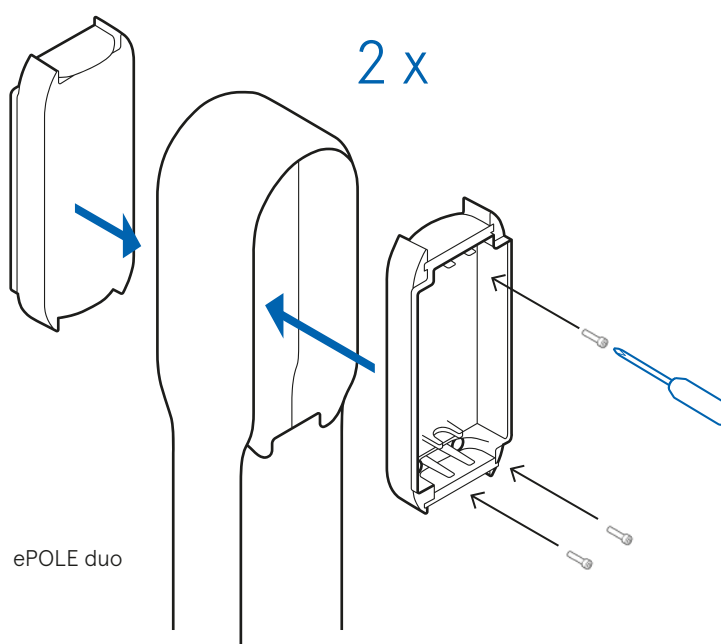

Compleo eCLICK wall installation

After choosing a suitable site and making all of the preparations, you can now install the eCLICK.



Danger

The eCLICK must be installed on a flat surface so that the eCLICK does not deform.

01

The eCLICK packaging contains a drilling template that simplifies the installation work. Use it as necessary. Draw the three drill points on the wall using the template and a spirit level, or drill directly through the positioned template.

For full accessibility to the eBOX, the upper hole should be 1,150 mm above the floor.

Standard height:
1,500 mm

For full accessibility
of charging only:
1,150 mm

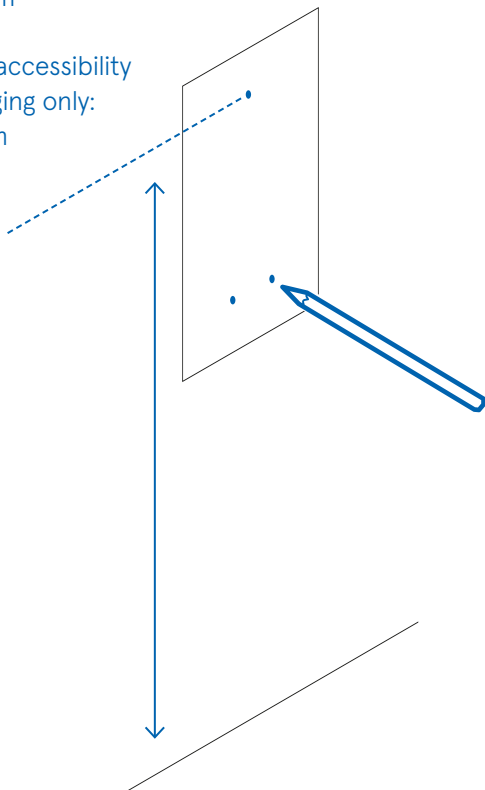

02

Drill the holes with an 8 mm bit, and insert the provided dowels. If the provided screws are unsuitable for the wall type at the chosen site, use another suitable type of attachment.

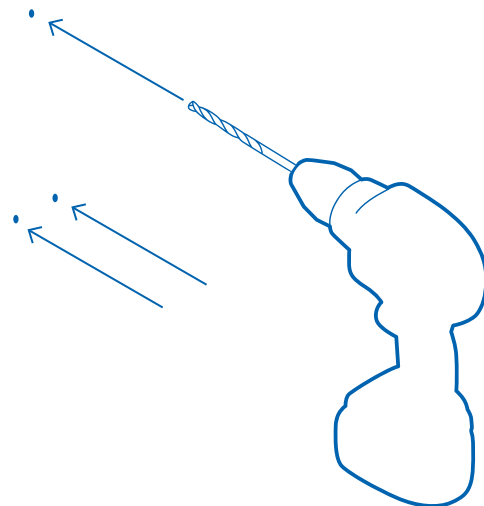

03

Screw the eCLICK to the wall using the screws provided.

04

Insert the provided sealing plugs.



Important

It is imperative that you insert the provided sealing plugs, otherwise water or other substances may penetrate and damage the product.

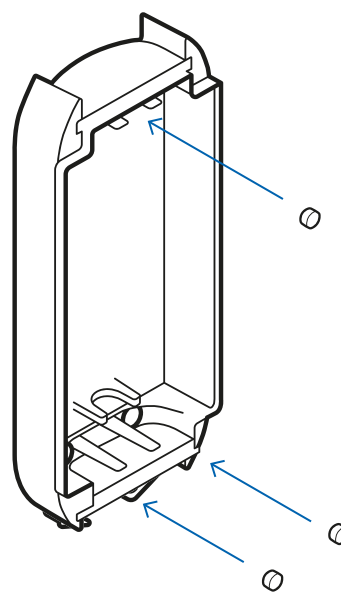
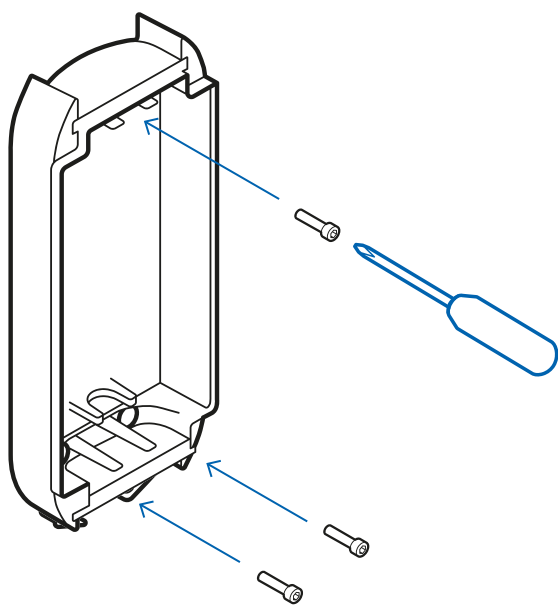

Integrating the Compleo eSMARTMETER (optional)

Included in delivery

1 eSMARTMETER
1 patch cable

Wiring cable not included.
Insert a cable with a maximum
cross-section of 10 mm².

Remove the contact guard from the eCLICK (cf. previous page). It will be placed back on the eCLICK at the end of the installation.

When delivered, the contact guard is snapped to four points on the eCLICK.

01

Push the eSMARTMETER into the marked position, and click it in.

02

Insert the loose ends of the pre-assembled cables into the top section of the eCLICK (mains board).

Supply cable connection

There are two connection options for the supply cable. The two options for single and double supply can be found from page 28 onwards.

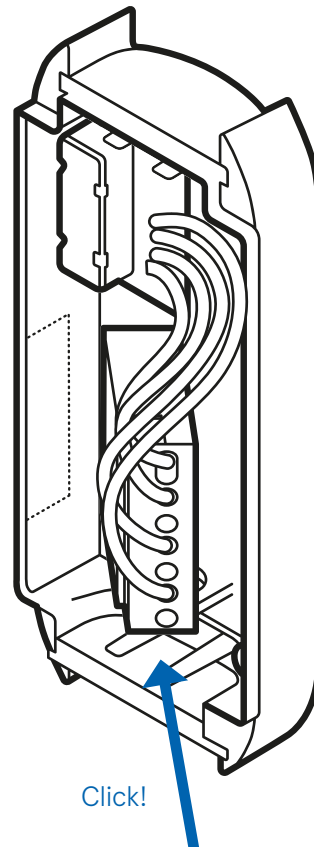

Compleo eSMARTMETER cabling

As the last step before installation, eSMARTMETER cabling must be carried out.



Important

The eSMARTMETER supply cables must be placed on the mains board.

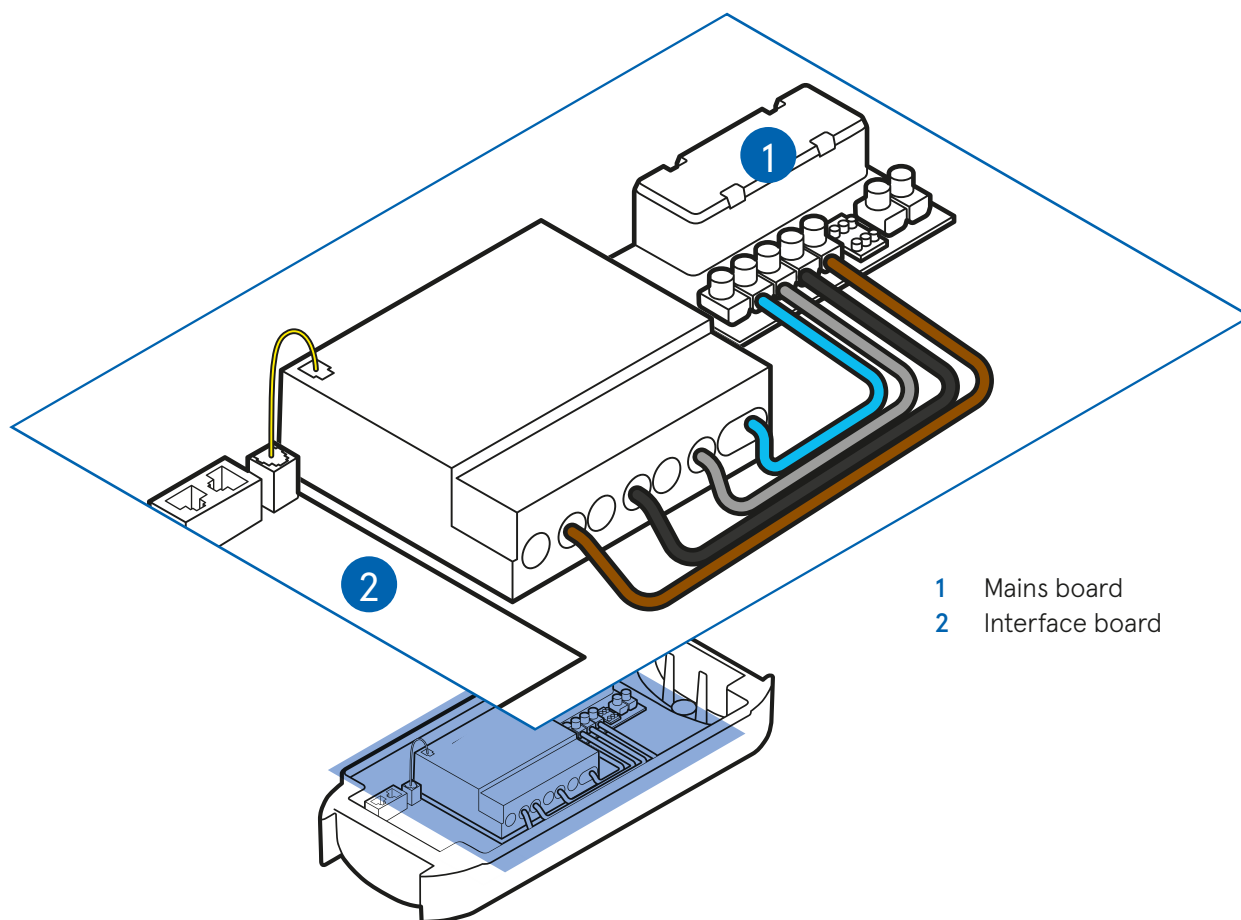

- 1 Mains board
- 2 Interface board

01

Consult the figure to wire the eSMARTMETER to the mains board, and tighten the screws with a torque of 1.2-1.5 Nm.

02

Use the provided data cable to connect the eSMARTMETER to the interface board.

Preparing the electrical connection

Make sure that the hole in the cable routing plate is facing the side where you want to insert the supply cable. If not, draw out and exchange the plates.



Important

When inserting the cable routing plates, it is essential to ensure that they are flush.

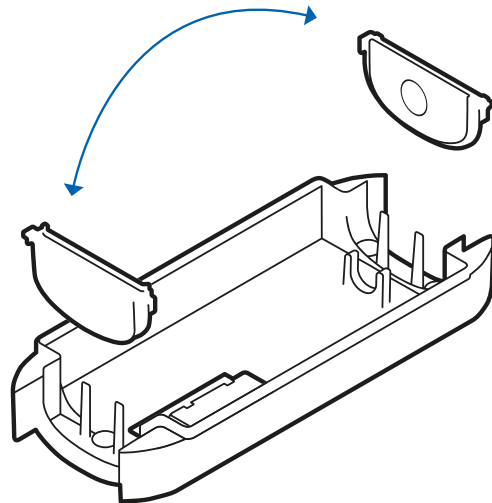

Ethernet link (optional)

An Ethernet cable can be used to integrate the eBOX in the customer's network. It is important to know the connections on the interface board for the Ethernet connection.

- 1 LAN 3 RJ45 (eBOX communication)
- 2a LAN 2 RJ45 (to Internet router)
- 2b LAN 2 LSA-Plus (to Internet router)
- 3a eSMARTMETER output (optional)
- 3b eSMARTMETER input (optional)
- 4 Cable clip position for S/FTP cable
- 5 RJ50 Terminal (eBOX communication)
- 6 Grid control box connection
- 7 Shunt release connection
- 8 LAN 1 RJ45 (deactivated)

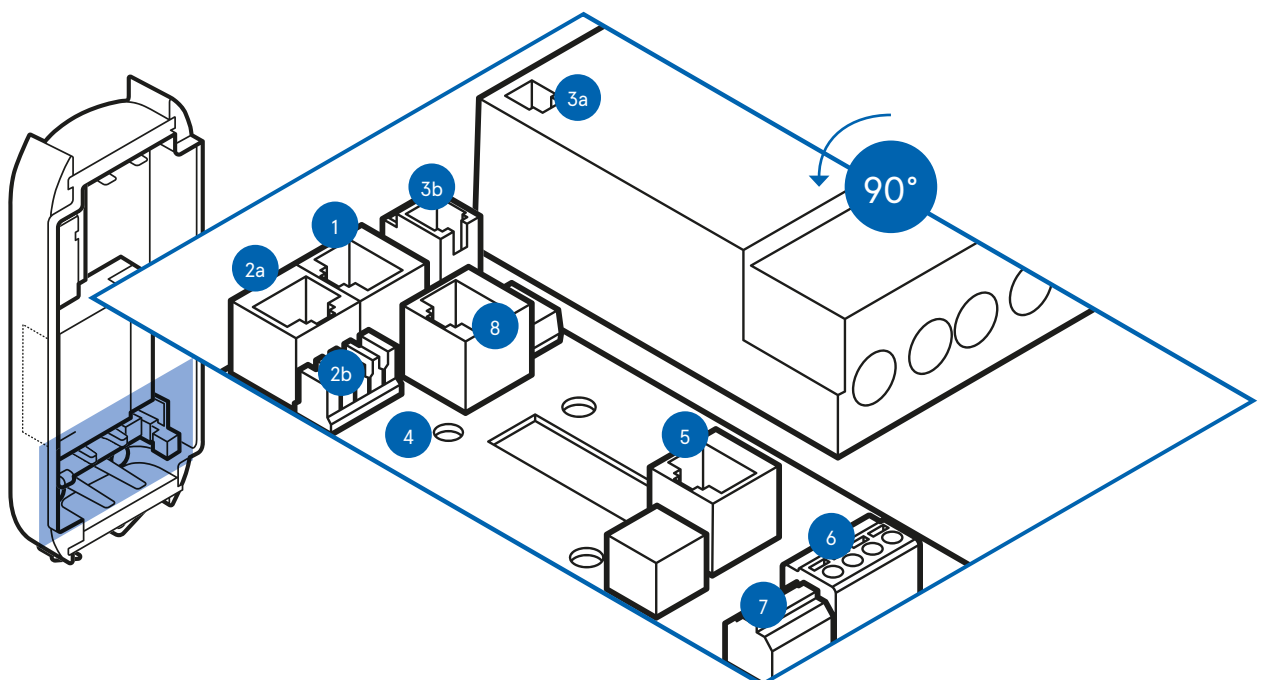

01

If necessary, drill a suitable hole (see dotted hole in the picture) for the M20 cable gland in the cable routing plate using the step drill. Drill step by step to ensure that the hole is not too large and that there is still a seal after the cable gland has been installed. Insert the M20 cable gland (for Ethernet, AUX supply etc.).

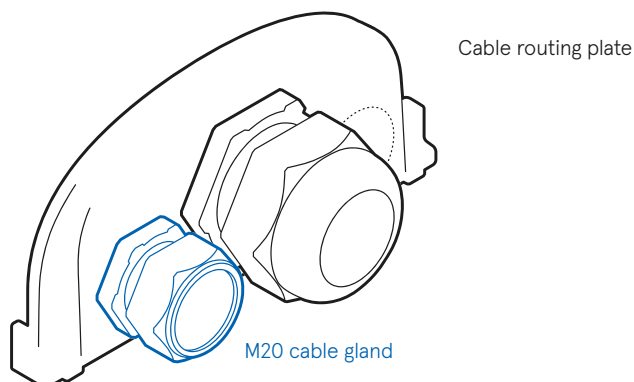

02

Replace the routing plate in the eCLICK, and press it on firmly to ensure tightness.

03

Feed the network cable through the M20 cable gland over the cable ducts and secure the cable to 4 using the cable clip. Route the cable to the cable clip, strip the insulation from the cable, and place it on the LAN2 LSA-Plus connector strip (2b) of the interface board using an LSA-Plus routing tool. Alternatively, the RJ 45 port LAN2 can be used.

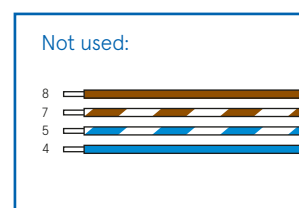
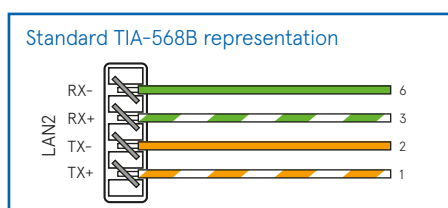
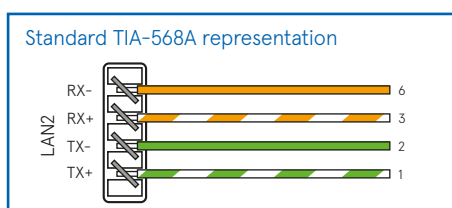
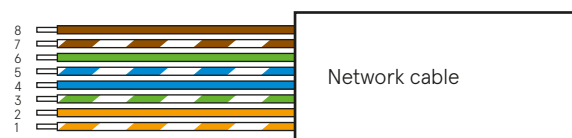

04

Firmly screw on the cable gland to ensure tightness.

Shunt release (optional)

The signal for welded power contacts is connected to position 7 of the interface board (see fig. p. 17). A change-over contact (max. 230 V, 1A) is available, which can be used according to the installer's requirements. A shunt release is an additional feature that must be connected as standard under IEC 60364 only. It is connected via screw terminal. Please note that the cable cross-section (rigid and flexible) must not exceed 0.2-1.5 mm².

12V/24V variant

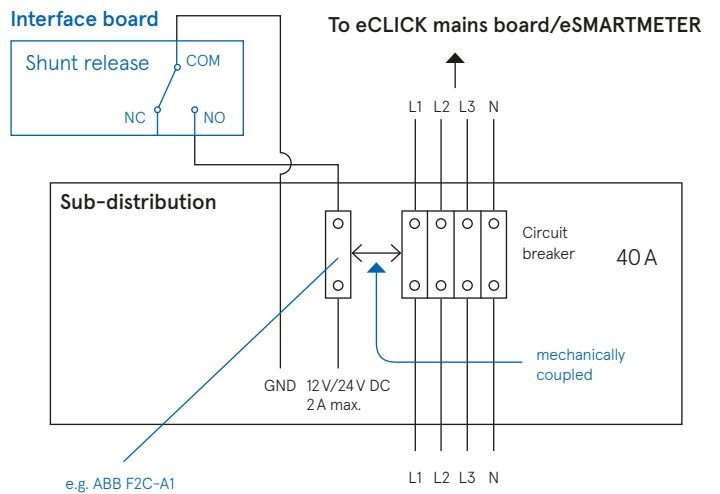

Grid control box connection (optional)

In the future, the eBOX can be controlled directly by the local grid operator with the help of a grid control box. The grid operator has the option of dynamically limiting the charging power over a maximum of 4 steps.

Please check the specifications of the local grid operators with regard to the power levels. They can vary depending on the grid operator and must be configured individually for your eBOX.

Grid control box connection

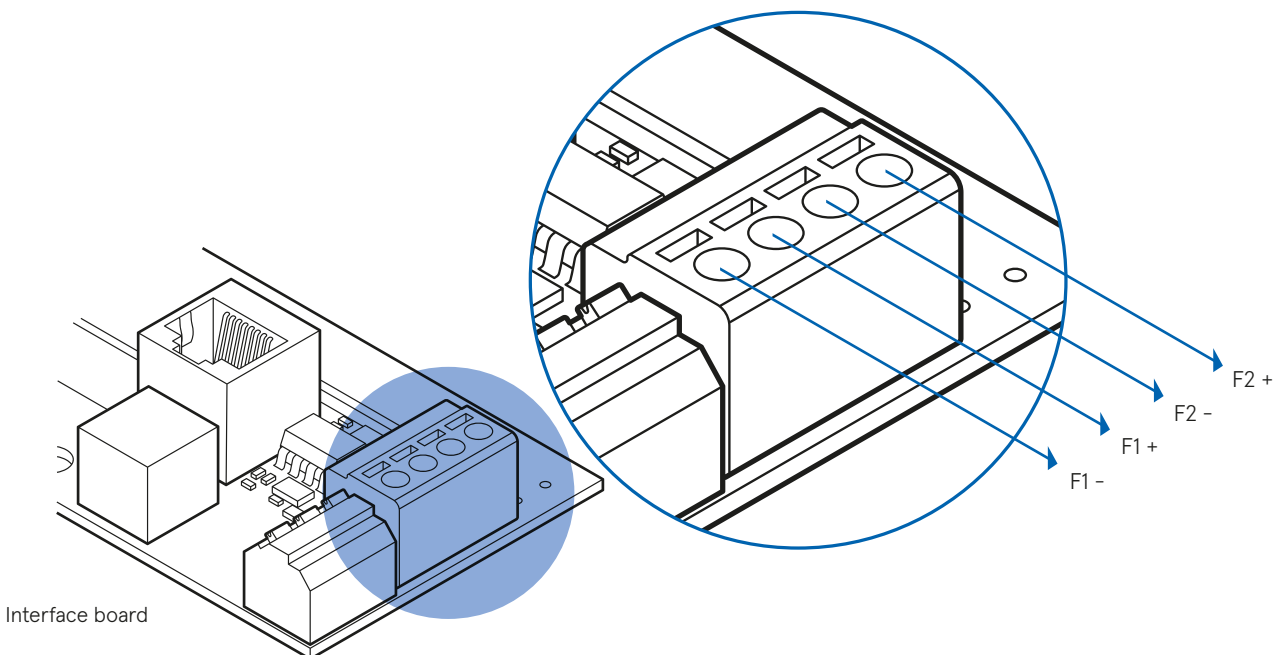

Connection

The grid control box connector can connect the eCLICK to an external control box. The interface board features 2 connection options for connecting the grid control box.

There are 2 potential-free contacts available. Please note the following specifics for cable installation:

- If only one grid channel is used:
2-core sheathed cable
- When using both grid channels:
4-core sheathed cable
- Maximum cable cross-section:
0.2 mm²-4 mm² rigid cable/
0.2 mm²-2.5 mm² flexible cable
- When installing the cable, please observe the specifications in the installation instructions for the grid control box.

Activation

Activation takes place in two stages:

1. Please perform initial commissioning via the eCONFIG app to establish a connection with the backend. The QR codes for downloading the app can be found on p. 35.

2. The grid control box connection is activated via WEBCONFIG. You can find the instructions in the Document Center at docs.compleo-cs.com

Before activation, note the switching states and the assignment of the different power stages. In the WEBCONFIG quick setup, you can activate grid with the predefined values (see table on the right).

Under "Advanced Settings" in WEBCONFIG, different power levels can be defined (e.g. 0%/30%/70%/100%).



Note

Communication between the grid control box and the eBOX takes place via the black ribbon data cable. Make sure that the eBOX data cable is connected to eCLICK.

Switching of potential-free contacts

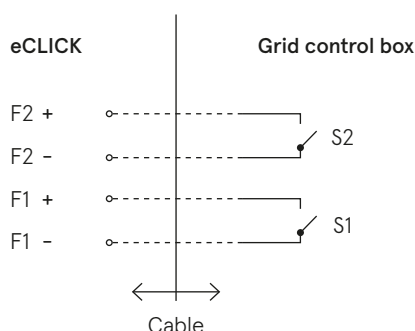

Important

There is a risk of confusion between the switching states with open and closed relay.

Predefined values for grid

S & W open: D%	100%
S open/W closed: C%	60%
S closed/W open: B%	30%
S & W closed: A%	0%

Electrical connection



Danger

Make sure that the fusing for the circuits has been disconnected and there is no voltage across the fitted components.



Important

The complete product – consisting of eCLICK, eBOX, and possibly ePOLE duo – has no facilities for the attachment of additional ventilation components.

Connecting options

The electrical connections (see scenario A, B, C, or D) differ depending on whether the eSMARTMETER is integrated or not.



Note

Supply cables are not included in the delivery.



Important

The eCLICK can be connected to both the single- and the three-phase output of the sub-distribution. Illustrated, however, are the three-phase connections only. If the connection is single-phase, connect only to **L1, N, and PE**.



Important

The conductor cross-section may not exceed 10 mm² (bending radii of the cables).

Installation is greatly simplified when the cable harness has been prepared for wiring before being inserted in the eCLICK. It is recommended to remove the routing plates, to insert the cable, and to pre-bend the cores according to your configuration. When doing so, consult the figures on the following pages.

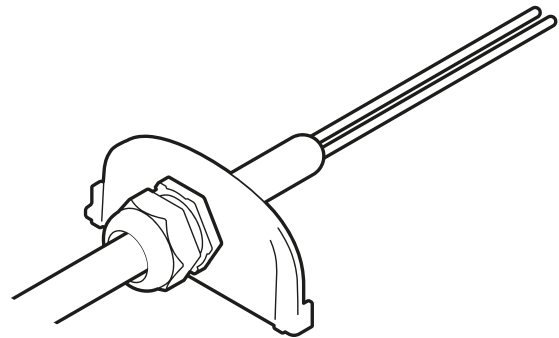

Scenario A: single power supply to the Compleo eCLICK without Compleo eSMARTMETER

Strip a generous length of insulation from the cable before inserting it in the eCLICK. This will simplify rerouting and subsequent eSMARTMETER installation.

Introduce the supply cable into the eCLICK from **the top (T)** or **the bottom (B)**. Now place the wires on the contacts as depicted in the figure, and tighten the screws on the terminals with a torque of 1.2-1.5 Nm.



Important

If single-phase connection is required, the mains board or eSMARTMETER must not be connected at L2 or L3!
The supply cable L1 must always be connected to L1 at the mains board or eSMARTMETER.

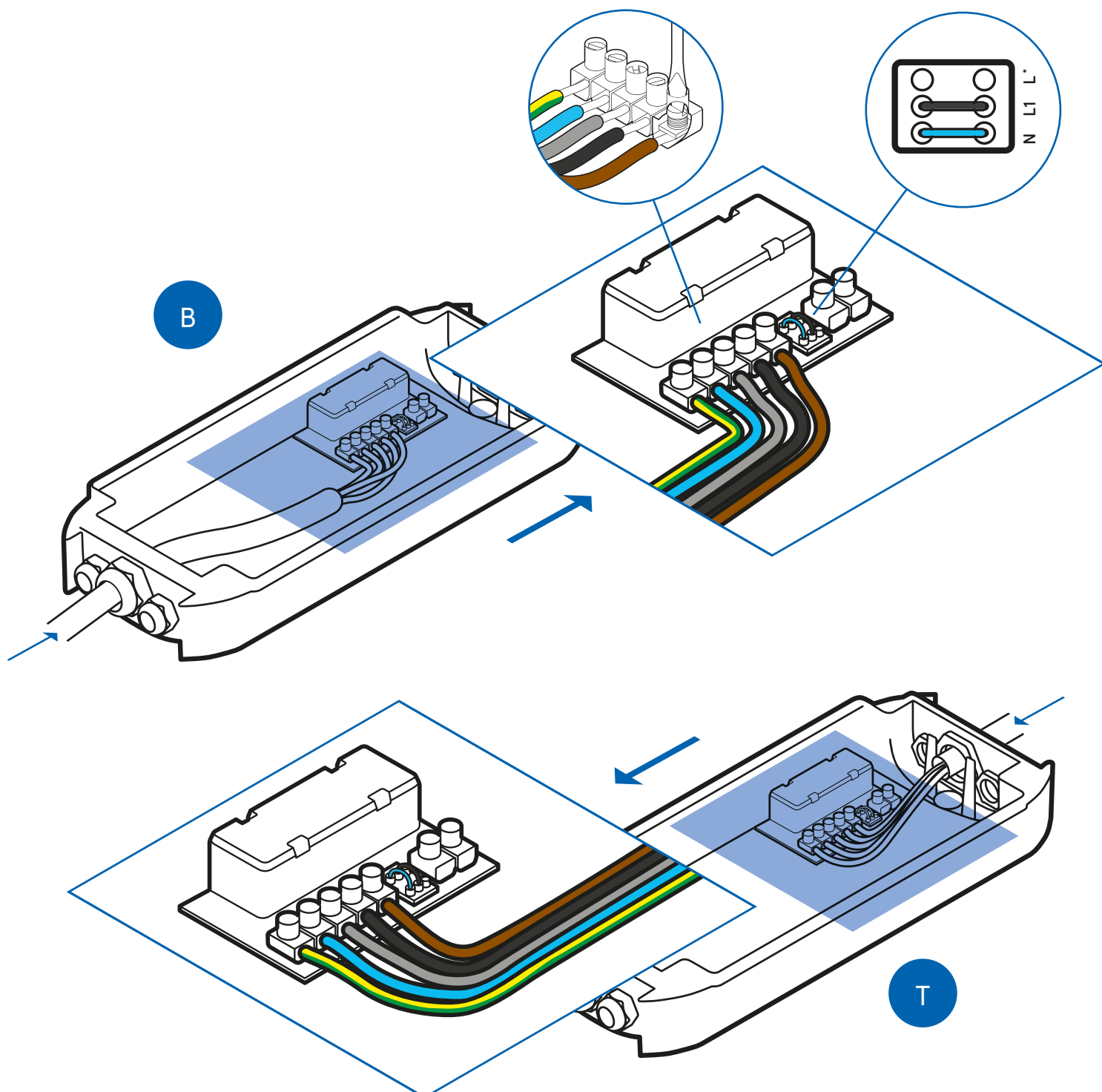

Scenario B: Compleo eCLICK electrical connection with Compleo eSMARTMETER, simple supply

1. Detach the cable routing plate from **the top (T)** or **the bottom (B)**.
2. Introduce the cable through the routing plate, and cut to length.
3. Replace the cable routing plate.
4. The eSMARTMETER supply cables must be placed on the mains board.
5. Transfer the black jumper from L1 to L*.
6. Now place the strands on the contacts as depicted in the figure, and tighten the screws on the terminals with a torque of 1.2-1.5Nm.



Important

If single-phase connection is required, the mains board or eSMARTMETER must not be connected at L2 or L3!
Supply line L1 must always be connected to L1 of the mainboard or eSMARTMETER.

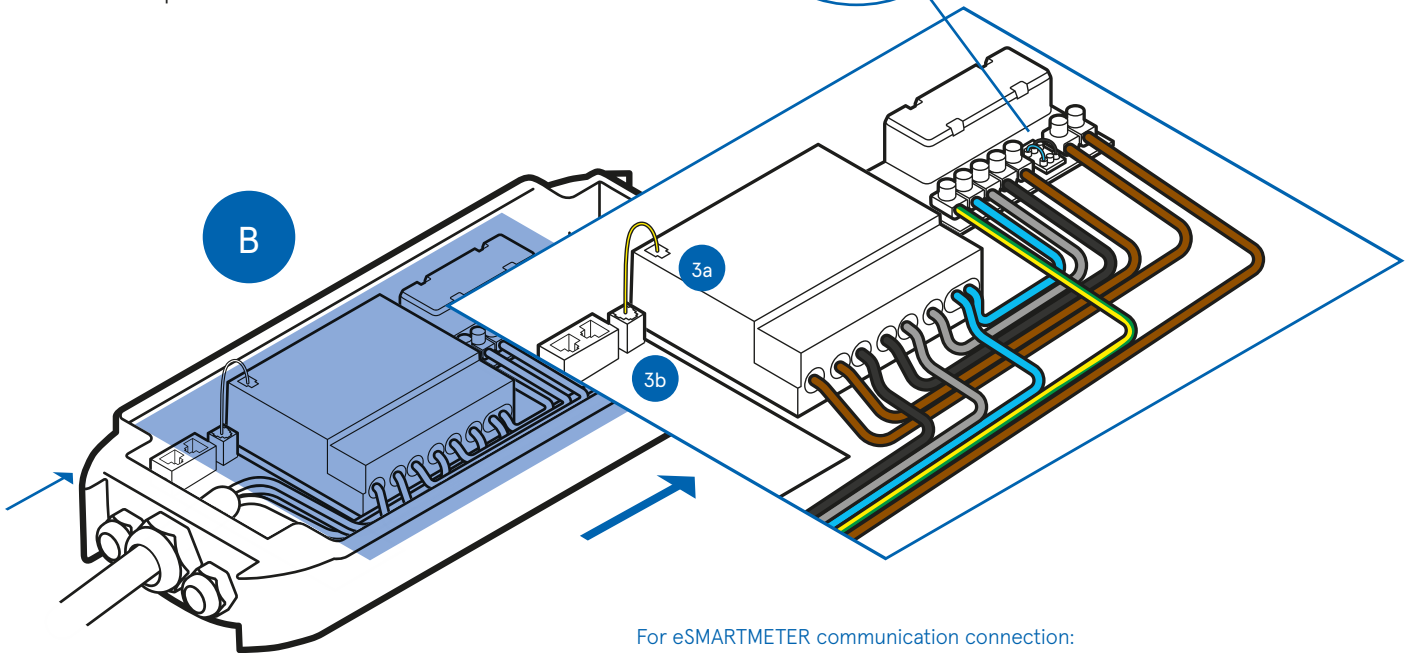
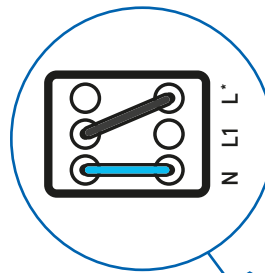

For eSMARTMETER communication connection:
Connect eSMARTMETER output **3a** to eSMARTMETER input **3b** (cable provided).

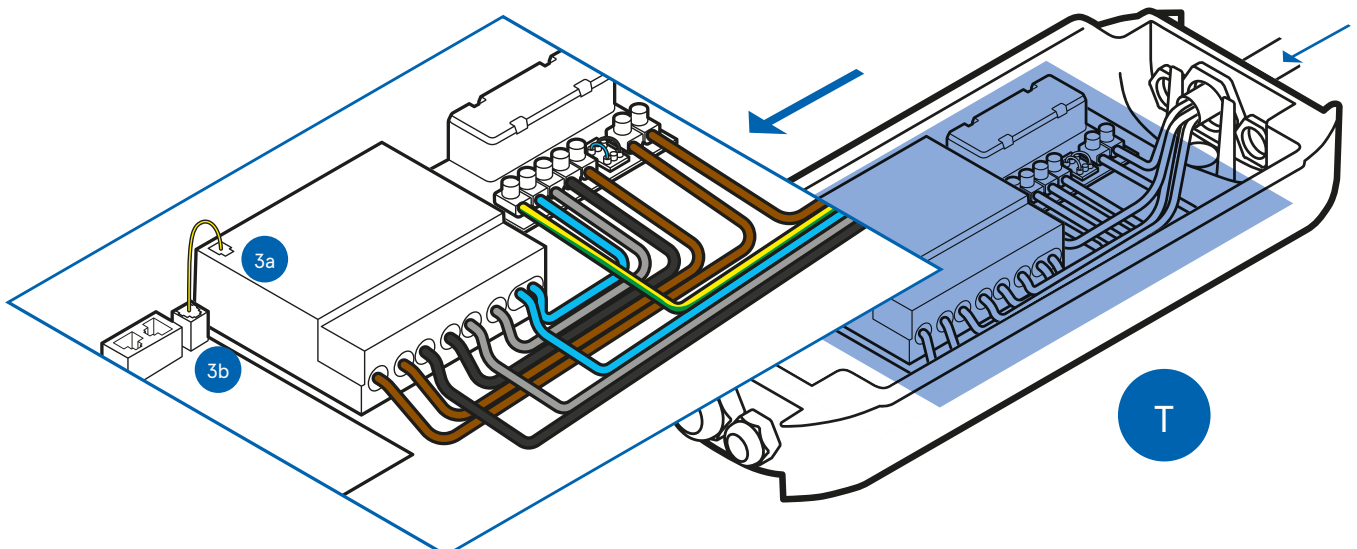

Scenario C: double power supply line to the Compleo eCLICK without Compleo eSMARTMETER (separate power supply line for self-supply)

Cut the cable to a length longer than necessary. This will simplify rerouting and subsequent eSMARTMETER installation.

1. Drill a hole for the AUX cable in the corresponding routing plate, and insert the provided M20 cable gland.
2. Replace the routing plate in the eCLICK, and press it on firmly to ensure tightness.
3. Firmly screw on the cable gland to ensure tightness.

Introduce the supply cable into the eCLICK from **the top (T)** or **the bottom (B)**. Before you can route the AUX lines, you must first remove the blue and black jumper on the mains board. Now place the strands on the contacts as depicted in the figure, and tighten the screws on the terminals with a torque of 1.2-1.5 Nm.



Note

The cable cross-section of the separate AUX supply line may not exceed 1.5 mm².



Important

If single-phase connection is required, the mains board or eSMARTMETER must not be connected at L2 or L3! Supply line L1 must always be connected to L1 of the mainboard or eSMARTMETER.

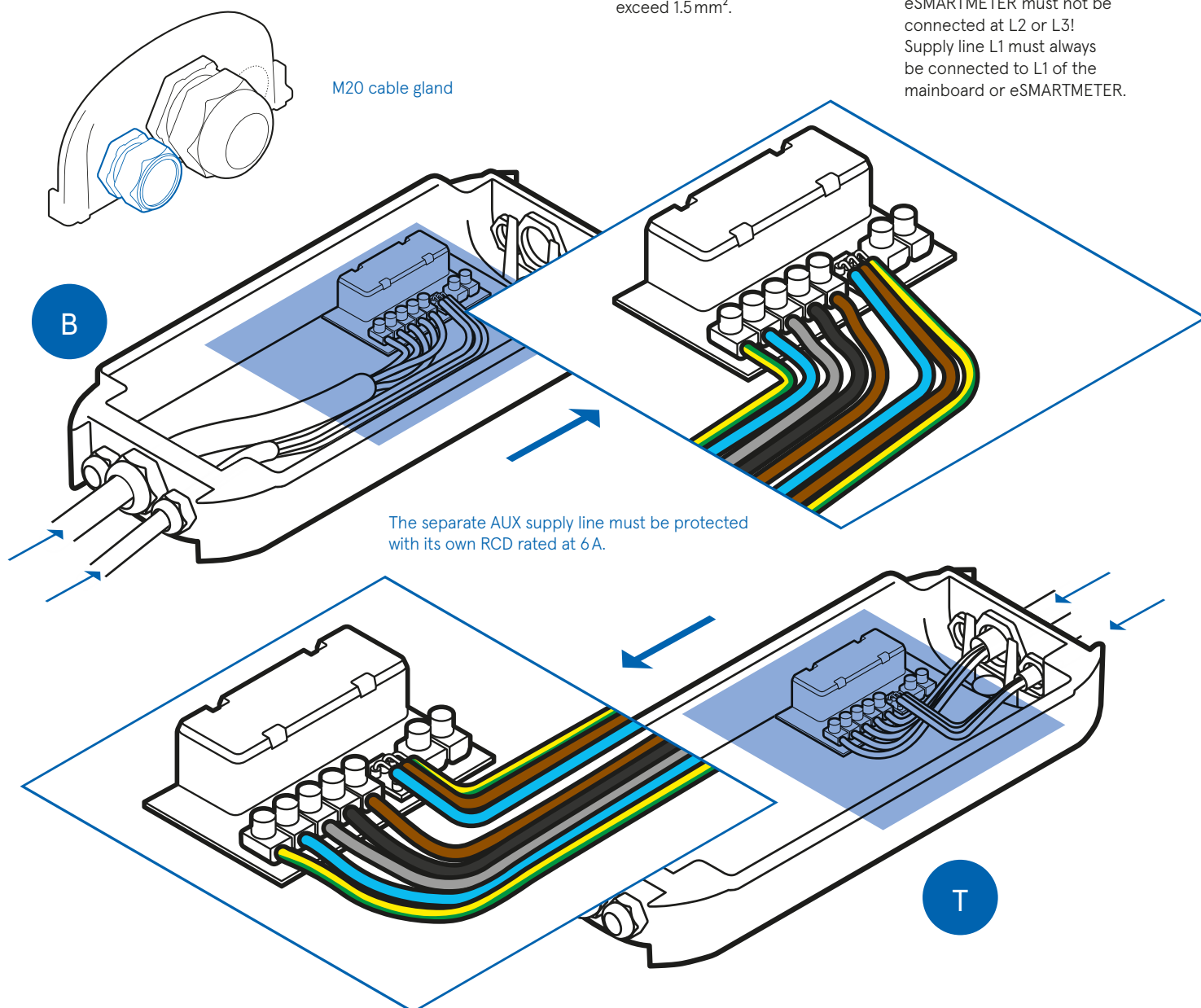

Scenario C: double power supply line to the eCLICK with eSMARTMETER (separate power supply line for self-supply)

General approach

1. Drill a hole for the AUX cable in the corresponding routing plate, and insert the provided M20 cable gland.
2. Replace the routing plate in the eCLICK, and press it on firmly to ensure tightness.
3. Firmly screw on the cable gland to ensure tightness.

Approach with Compleo eSMARTMETER

Remove the cable routing plate from **the top (T)** or **the bottom (B)**. Insert the cables through the cable routing plate and cut them to length. Then replace the cable routing plate. The eSMARTMETER supply cables must be placed on the mains board. Transfer the black jumper from L1 to L^{*}. Now place the strands on the contacts as depicted in the figure, and tighten the screws on the terminals with a torque of 1.2-1.5 Nm.



Important

If single-phase connection is required, the mains board or eSMARTMETER must not be connected at L2 or L3! Supply line L1 must always be connected to L1 of the mainboard or eSMARTMETER.



Note

The cable cross-section of the separate AUX supply line may not exceed 1.5 mm².

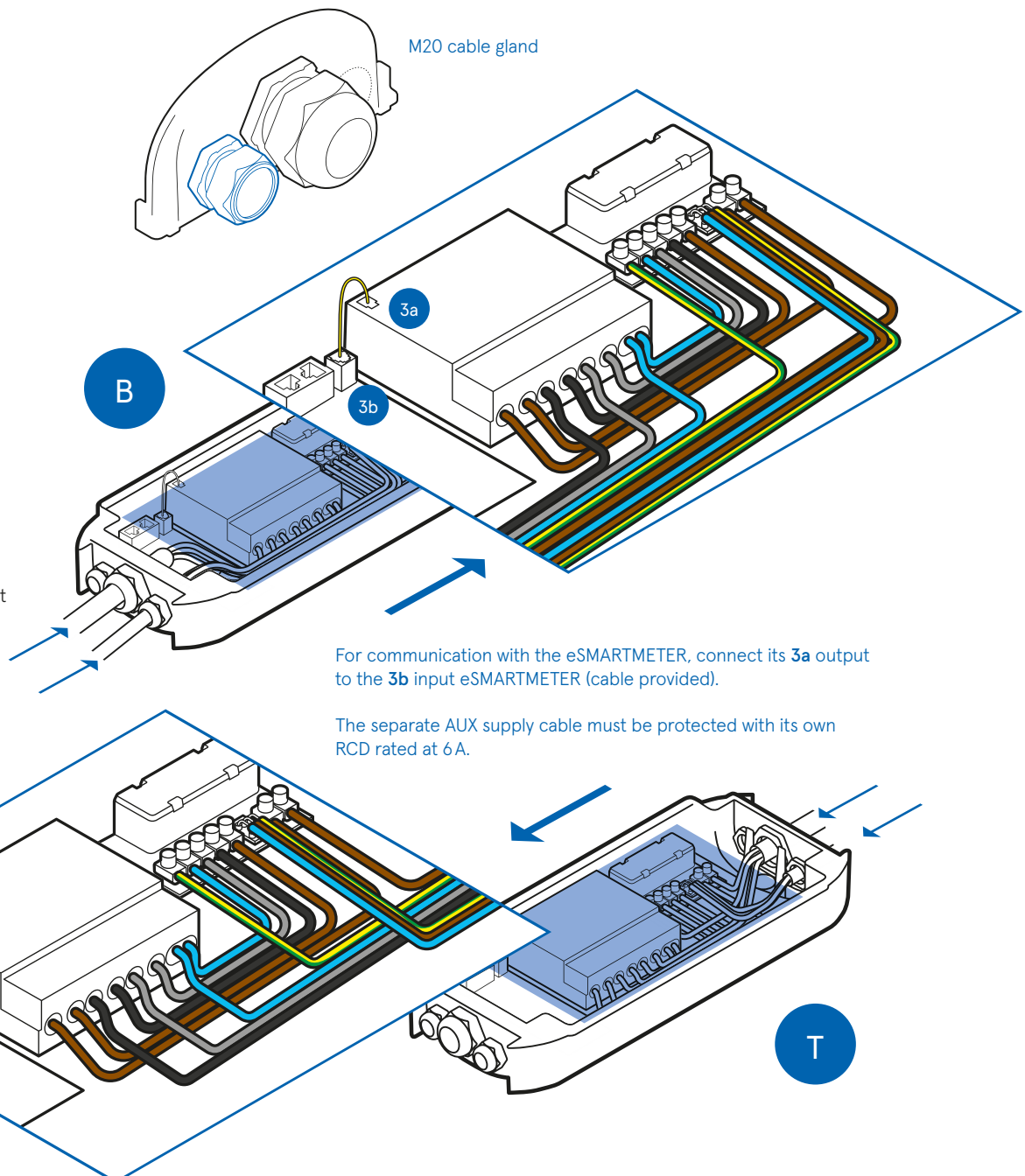

Reading the meter

If an eSMARTMETER has been installed, read the energy value, and note it alongside the meter number.

eSMARTMETER

Meter number	
Meter reading	
Reading date	

Almost done: electrical tests and sealing

Once all cables have been configured and secured as depicted in the respective figure, tighten the screws as necessary. In order to be able to carry out electrical tests, the voltage may be switched on. Afterwards, the system must be disconnected again.

1. Switch off the voltage after completion of the test in accordance with national electrotechnical standards.
2. Put the contact guard back into place on the eCLICK.
3. Use the provided seal to secure the contact guard on the eCLICK in such a manner that unauthorised removal of the contact guard is not possible without breaking the seal.

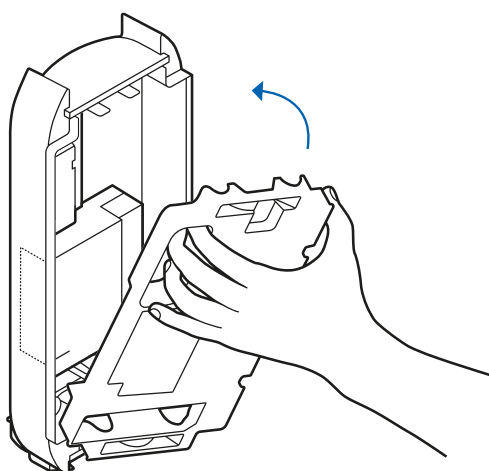

Danger

There is a risk of electric shock and danger to life and limb.



Important

Observe the requirements under IEC 60364. Specifically:

- The PE/N voltage may not exceed an effective value $U_{\text{eff}} = 10\text{ V}$. If this value is exceeded, locate and remedy the cause.
- Measure the earth resistance. It should be less than $100\ \Omega$.



Danger

After installation, the mounted eCLICK must be covered in a suitable manner. If the eBOX is to be installed at a later time, switch off the power supply to the supply line until then and secure it against being switched on accidentally.

Clicking the Compleo eBOX into the Compleo eCLICK

After the electrical installation, the eBOX can be clicked into the eCLICK.

Before installing the eBOX, make sure the supply to the eCLICK is disconnected.

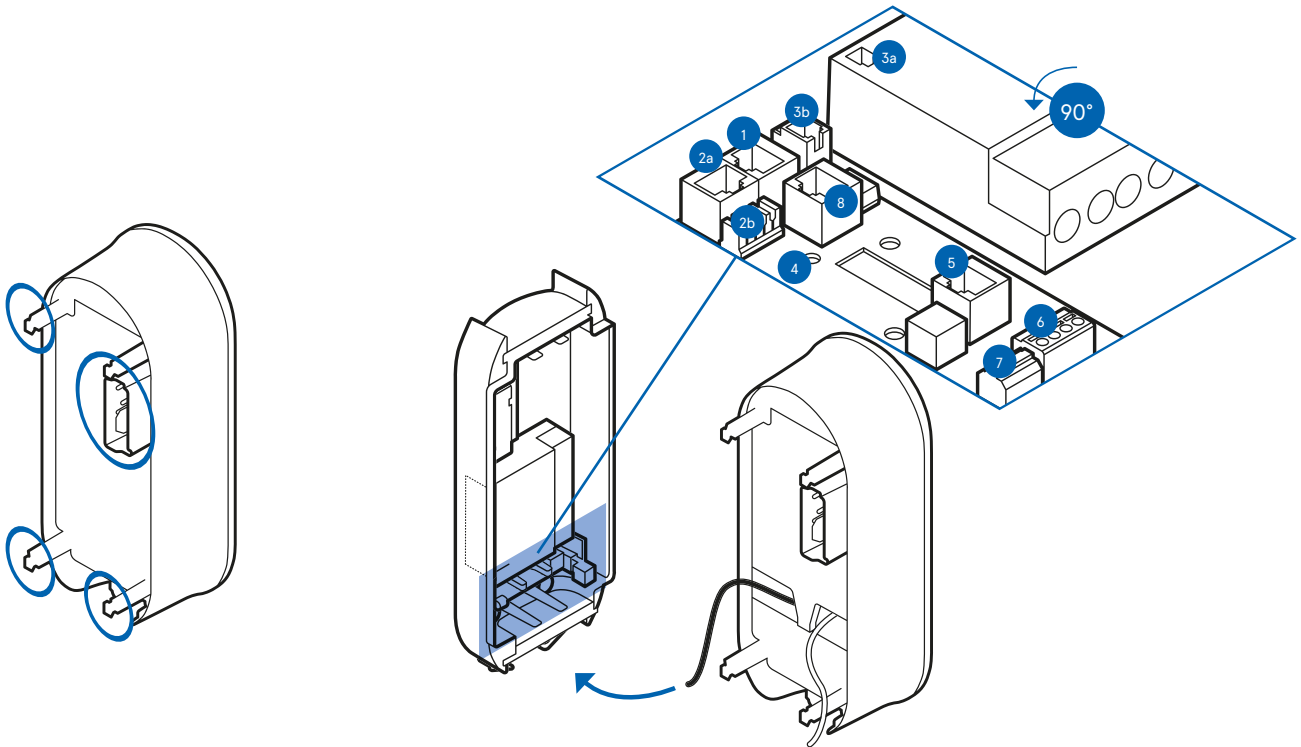

01

If an eSMARTMETER is installed, make sure the ports are connected to the supplied data cable. Connect port 3a (eSMARTMETER) to port 3b (eCLICK) using the data cable.

Take the eBOX and identify the connecting points (blue here) on its rear side.

02

Connect the black ribbon data cable of the eBOX to the port "5 Expansion Terminal" at the bottom right of the eCLICK.

03

Connect the white ribbon data cable of the eBOX to port 1 on the left side of the eCLICK. Communication via LAN or SIM card can only be ensured when the black and white ribbon data cables are connected.

- 1 LAN 3 RJ45 (eBOX communication)
- 2a LAN 2 RJ45 (to Internet router)
- 2b LAN 2 LSA-Plus (to Internet router)
- 3a eSMARTMETER output (optional)
- 3b eSMARTMETER input (optional)
- 4 Cable clip position for S/FTP cable
- 5 RJ50 Terminal (eBOX communication)
- 6 Grid control box connection
- 7 Shunt release connection
- 8 LAN 1 RJ45 (deactivated)



Important

Make sure that the flat ribbon data cables are not trapped between the eCLICK and eBOX when mounting the eBOX.

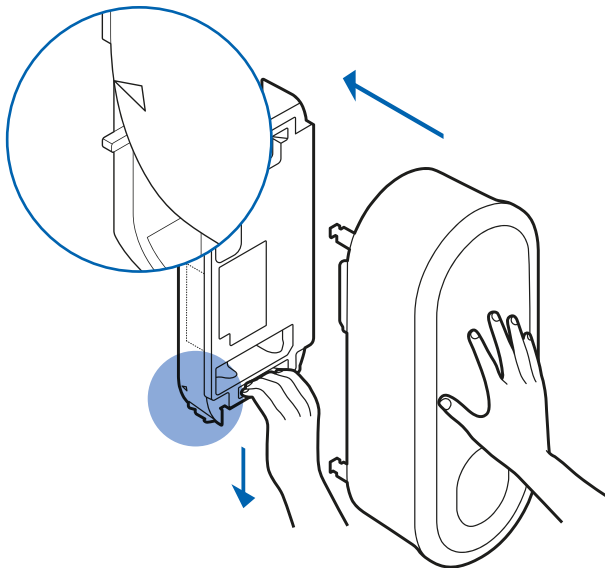

04

Please prepare the installation by pulling down the locking bracket completely and ensuring to hold it firmly in this position. Now place the eBOX carefully on the eCLICK and push it firmly in the middle with the other hand until it stops. Be careful not to exert excessive pressure on the circle LEDs.

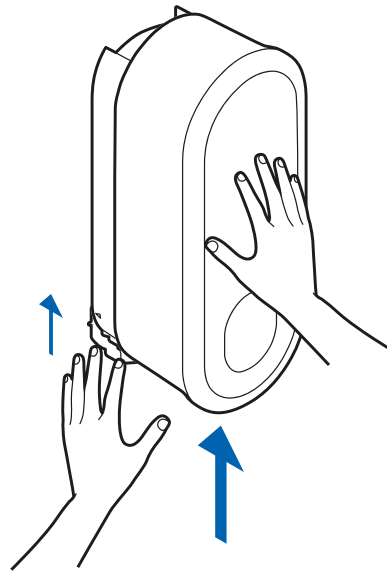

05

Now release the bracket and let it lift automatically. Please hold the eBOX in place with one hand.

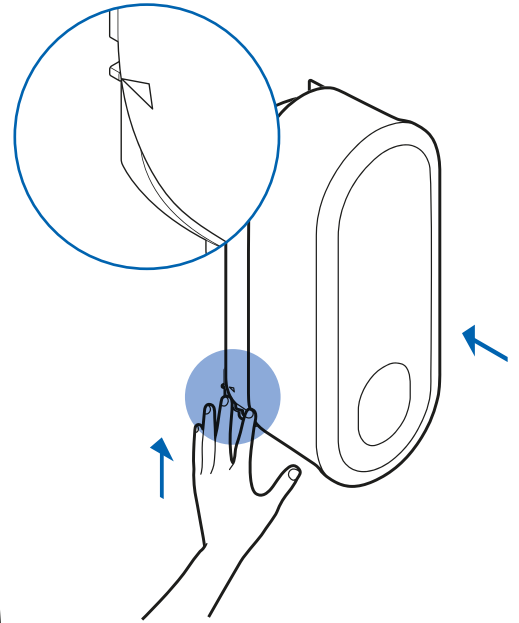

06

Please continue to hold the eBOX in place with one hand. Check the final position of the locking bracket, it must be fully raised. The enlarged detail view demonstrates the desired final position. The pin on the locking bracket must be exactly level with the triangle on the eBOX. If the bracket has not reached the desired final position, please push it further upwards to the desired final position.

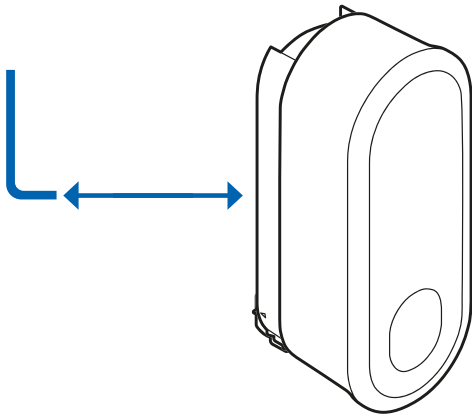

Important

Make sure that the eBOX clicks correctly into the eCLICK. Marking of the locking bracket is in final position.
The grub screw must be fully screwed in.
Check eBOX for firm attachment.



Note

The grub screw can only be fully screwed in when the locking bracket is inserted completely.

07

Tighten the pre-installed grub screw on the eCLICK using the allen wrench to secure the locking mechanism in place and to secure the eBOX on the eCLICK against unauthorised removal.

08

Now the eBOX is mounted on the eCLICK.
Power on the eCLICK circuit.

Installation completed!

Checklist

Please read and follow the installation instructions completely.

- Sealing plug inserted
- Cable routing plates inserted flush
- Contact guard attached
- Contact guard secured with seal
- Ribbon data cable between eCLICK and eBOX not jammed
- Locking bracket in final position
- Electrical final inspection successfully completed
- Function test successfully carried out (if eBOX is available)



Important

Please note down the number of phases you have connected and the maximum current on the next page of these installation instructions and on the adhesive label affixed to the eCLICK. The customer can then configure the system independently after a replacement.

Commissioning the Compleo eBOX

After the preceding steps, you can switch in the voltage.

Bear in mind that the eBOX does not light up until you have approached it within one metre. You will be prompted to link to the eBOX via Bluetooth. To make this work, you need either the eCONFIG app or WEBCONFIG. The eCONFIG app is the easiest way to commission the eBOX. If you want to perform one or more of the following steps during commissioning, please use WEBCONFIG:

- Firmware Update
- Read out log files
- SIM card settings
- Standard config data upload

System commissioning must be carried out by an electrician.

I.) Configuring via Compleo eCONFIG app

You can download the required app via the following QR code:

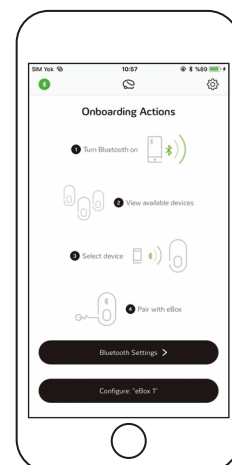

II.) Configuration via WEBCONFIG

You can download the instructions for using WEBCONFIG via the following link:



III.) Commissioning during installation for private use:

1. Adjust the installed charging capacity in the **eCHARGE+** app by selecting the number of connected phases and the installed amperage.
2. To set up the eBOX for the user, you can find more information on the approach at docs.compleo-cs.com.

IV.) Commissioning for a (semi-)public installation (commercial customer):

1. Adjust the installed charging capacity in the **eCONFIG app** or via **WEBCONFIG** by selecting the number of connected phases and the installed amperage.
2. You have the option of connecting your eBOX to the **Compleo backend** or a **third-party backend** of your choice:

Via Compleo backend

With your purchase of the eOPERATE software service, your product's system was automatically configured to your specified e-mail address. Please use the eOPERATE portal for any configuration and administration. You have received the initial password by e-mail. If you no longer have it, you can reset your password at eoperate-portal.com.

Via OCPP/third-party backend

Please contact your backend provider if you have any questions about the system configuration.

After commissioning, the eBOX enters standby mode. Now you can connect and charge a vehicle. The charging process is described in detail in the instructions for use provided with the eBOX (also available online).

Congratulations!
You have successfully
completed the installation.

Configuring the power connection



Please mark!

Other:

Number of phases	1	3	
Maximum current	16 A	20 A	32 A



Important

Please also enter the number of phases and the maximum current on the sticker on the eCLICK.

Maintenance/repair

The eCLICK is a maintenance-free product. It does not contain any repairable parts or components. Do not carry out any repair work. In case of a permanent error, replace the eBOX on the eCLICK or the eCLICK if required.

Disassembly

Disassembly of the eCLICK must be carried out by a qualified electrician.

To disassemble the eBOX, you first have to disconnect the power supply. First unscrew the grub screw on the side and remove the eBOX from the eCLICK by pulling down the locking bracket, removing the charging unit and, if necessary, the Ethernet cables which connect the eBOX and the eCLICK. Then remove the contact guard from the eCLICK

and disconnect the power cable and, if necessary, the Ethernet cable of the local network. Unscrew the cable gland(s) and remove the supply cable and, if necessary, the Ethernet cable(s). In the following step, the eCLICK can be unscrewed. Finally, you can remove the eSMARTMETER and replace the contact guard. The disassembly of the ePOLE duo is described in the corresponding installation instructions.



Danger

The eCLICK must be disconnected from the power supply before disassembly.



Important

Make sure that all components are dry during disassembly.



Important

When disassembling the eBOX, make sure that the eBOX is carefully removed from the eCLICK so that the flat ribbon data cables, the eCLICK and the eBOX are not damaged during disassembly.

Disposal

The eCLICK and the eBOX are electrical devices. These must be disposed of accordingly in compliance with the EU Directive WEEE II, the ElektroG of 20 October 2015 in Germany, or the VREG, SR 814.620, of 14 January 1998 in Switzerland.

Certificates



As of: 03/2022
Document Center:



Imprint

Copyright © 2022 Compleo Charging Technologies GmbH.
All rights reserved. This document is intellectual property
right- and copyright-protected. No part hereof may be edited,
duplicated, or published in any manner purposing other than
the proper use of the eBOX without express written permission
of Compleo Charging Technologies GmbH.

Compleo Charging Technologies GmbH

Oberste-Wilms-Straße 15a
D-44309 Dortmund
Germany

Head office: Dortmund, Germany
Registered as a company at Dortmund Local Court,
trade register no. HRB 30359

Compleo Charging Technologies GmbH

Oberste-Wilms-Straße 15a
D-44309 Dortmund | Germany

servicedesk@compleo-cs.com
compleo-cs.com

UK sales partner

Compleo Charging Solutions UK Limited
6th Floor | 60 Gracechurch Street
London | EC3V 0HR | Great Britain